

SMOKE SIGNAL ORANGE

datasheet



The Comet Smoke Signal Orange is a compact, flat top distress signal designed to be easy and safe to handle. It provides effective position marking during rescue operations and can be used to indicate wind direction, producing dense orange smoke for a minimum of 3 minutes.

✓ APPLICATION

The Comet Lifesmoke is a small and compact distress signal for daylight use designed for stowage in liferafts.

- Signal for position marking during rescue operations
- Indicates wind direction
- Safe use on oil or petrol covered water
- Conforming to SOLAS 74/88 as amended
- Ideal also for leisure boats

✓ STORAGE

This compact unit is ideally stored in a water-resistant locker at ambient temperature allowing easy access in an emergency or in the robust, specially designed polybottle.

✓ OPERATION



1. Remove plastic cap. Point away from body.
2. Pull ring firmly away from canister. Ensure hand remains clear of HOT END.
3. Throw Lifesmoke overboard immediately. Smoke will be emitted after a 2 second delay.

WARNING:

- Produces dense orange smoke - do not inhale
- Do not fire in a confined space
- Keep out of reach of children
- Only for emergency use at sea
- If damaged or dented do not use
- Do not dismantle
- Keep away from source of heat
- Do not use after expiry date



DISPOSAL:

- Pyrotechnics must be treated as hazardous items and must be disposed of responsibly in accordance with local regulations. For help and advice, visit our website www.comet-marine.com

Art No.

9162000



Safety of life at Sea (SOLAS)



Marine Equipment Directive (MED)

SMOKE SIGNAL ORANGE

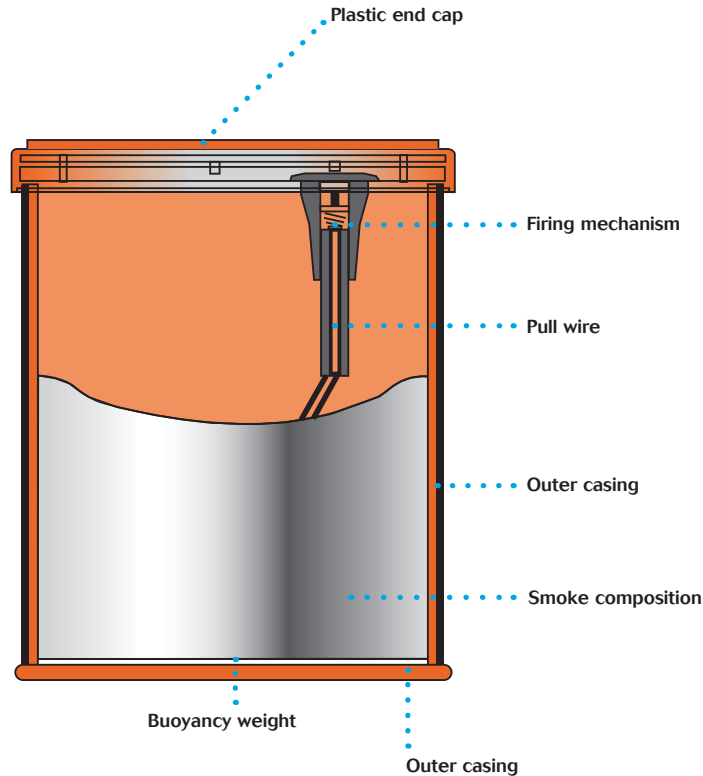

✓ SPECIFICATIONS:

- Height: 100 mm (4 ins)
- Diameter: 84 mm (3.3 ins)
- Weight: 340 g (11.9 oz)
- NEC: 200 g (7 oz)
- Burning time: 3 minutes minimum
- Colour of smoke: orange
- Ignition: pull-wire ignitor with 2 seconds safety delay

✓ APPROVALS

Conforms to: SOLAS 74/88 as amended, IMO resolutions (MED) 96/98/EC, SBG 423.006, USCG and other major maritime authorities worldwide.

✓ PACKING & TRANSPORT INFORMATION

- 24 signals in 1 fibreboard box
- Gross weight 9.5 Kgs (21 lbs)
- Net weight 8.88 Kgs (19.58lbs)
- Measurements of fibreboard box: 36 x 27 x 22 cms (14 x 11 x 9 ins)
- Net Explosive Content per box: 4.8 Kgs (10.6 lbs)
- Hazard Class 1.4S
- UN 0507
- Proper Shipping Name: Signals, Smoke

Authorised Dealer

ADEC MARINE LIMITED
4 MASONS AVENUE
CROYDON, CRO 9XS, UK
TEL 020 8686 9717
sales@adecmarine.co.uk